



BLIK SEPARATION: Vibrating tables, Trommels

*BLIK SEPARATORS are 2 types: vibrating tables and Trommels.
Alone - or in output of a crusher, they automatically sort the material into two or more phases of different granulations, without any manutentions
Robust, modular, adaptable, they are outstanding productivity tools. They are ideal for the separation of most materials*

Vibrating table BLIK Serie TIBY 1500-500, 2 motors



Blik crusher B600 and vibrating table BLIK in output

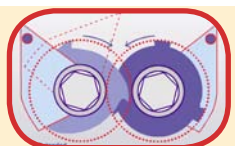
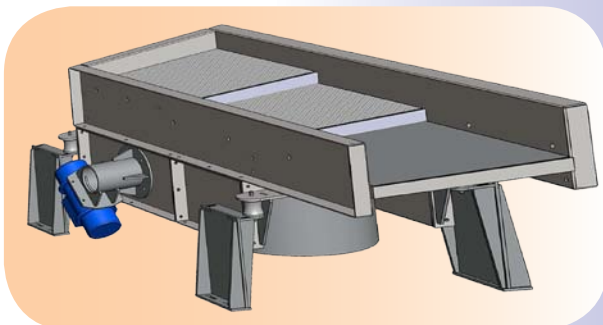
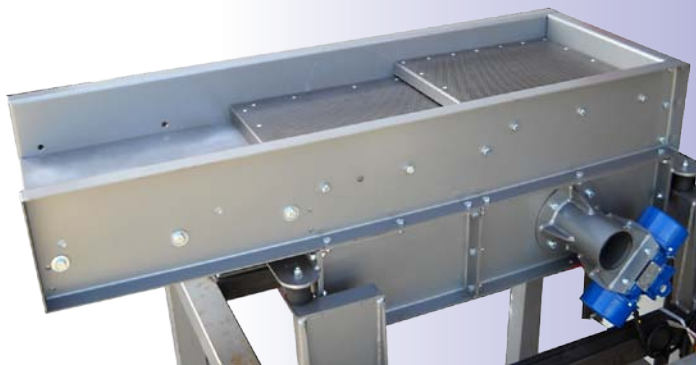

BLIK



www.blik.fr

BLIK - Waste Recovery and Processing Equipment
Z.I. de Chenet
91490 MILLY-LA-FORET
E.mail: blik@blik.fr

telephone:
33 (0)1 64 98 79 79
fax:
33 (0)1 64 98 79 78

Vibrating table BLIK Serie TIBY 1500-500, 2 motors

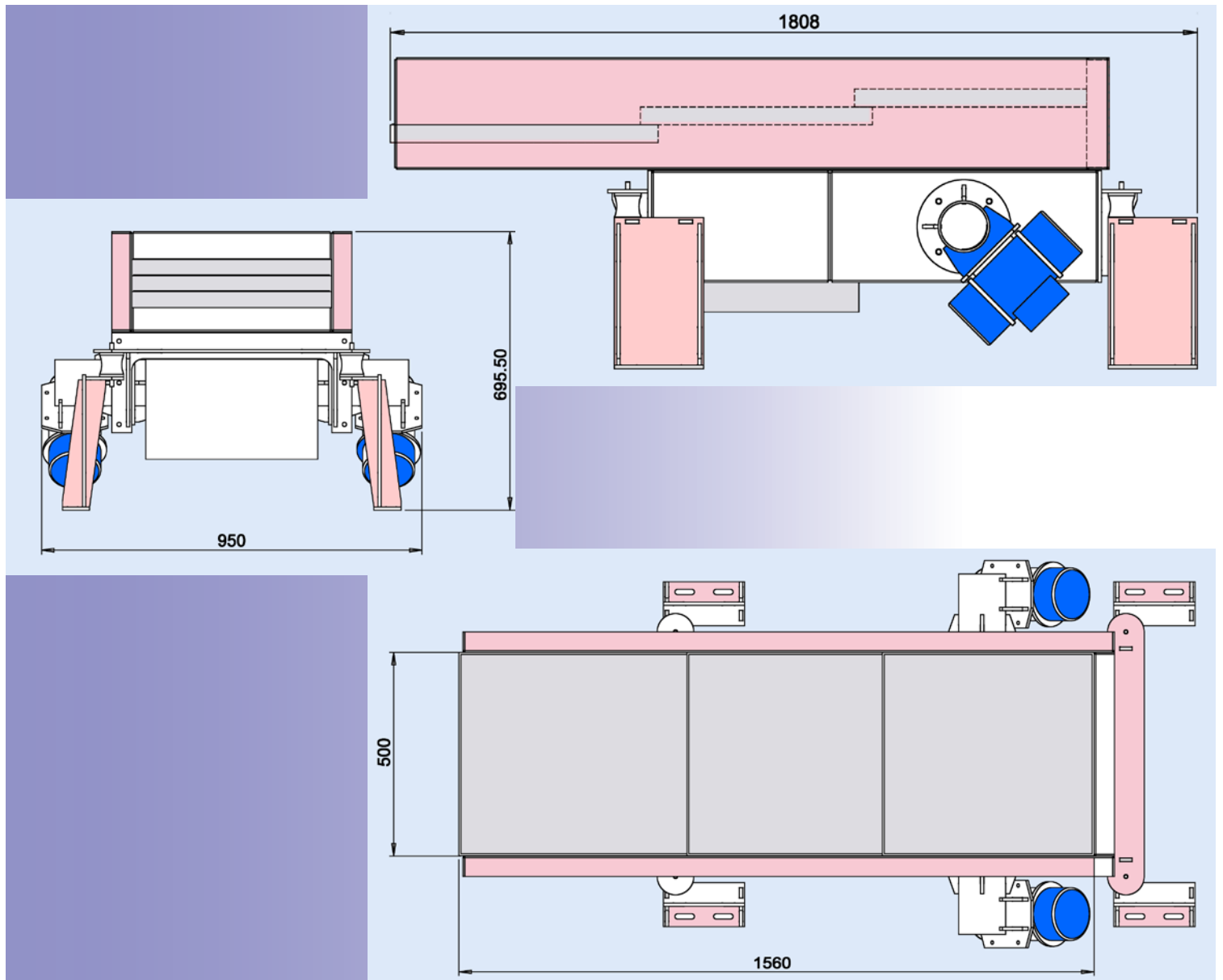

VIBRATING TABLE BLIK TIBY 1500-500 : Width 500 mm lenght 1500 mm

Effective width of the screen segment	420 mm
Total length	1550 mm
effective lenght of thre screen	880 mm
Interchangeable screen segments	
Diameter of screen holes	according to thr tries
Motors	2 moteurs à balourd à masse réglable
Angle of motors	adjustable
Power motors	three phases 200W / 400V / 50Hz
Outside dimensions (mm) without stand support width x depth x Height	1808 x 950 x 696 mm
Debit	Varies depending on product flow to be treated
refusal sorting falls at the end of screen	
Weight (KG)	approx 450
"CE" certified - 1 year guarantee (*) –	Subject to technical and optical modifications
Options	Feed hopper; chassis standard support