

BLiK CRUSHERS B 840 Serie, 2 Rotors

The french manufacturer, BLiK, designs, studies, develops and manufactures “universal” crushers with rotating blades for a wide range of industrial purposes

These uniquely designed crushers come in a variety of configurations ranging from 2 to 30 kW and benefit from special design patents which make them easy to run and to service.

The B840 series crushers are two-shaft crushers with rotating blades which can handle a wide range of materials. Power: 30kw - cutting width: 758 - 1250 mm.

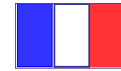

**French
Design and
manufacture**

Possible Options

- VL TYres
- Steel barrels
- Plastic Containers
- Batteries for cars
- Bulky refuse
- Special waste
- Pallets

CAPACITY:

- VL TYRES : 3 t/Hour
- PLASTIC FILMS : 2 t / Hour
- Metallic Barrels : 50 pieces/ Hour

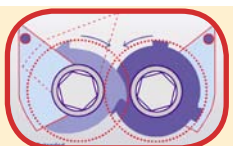
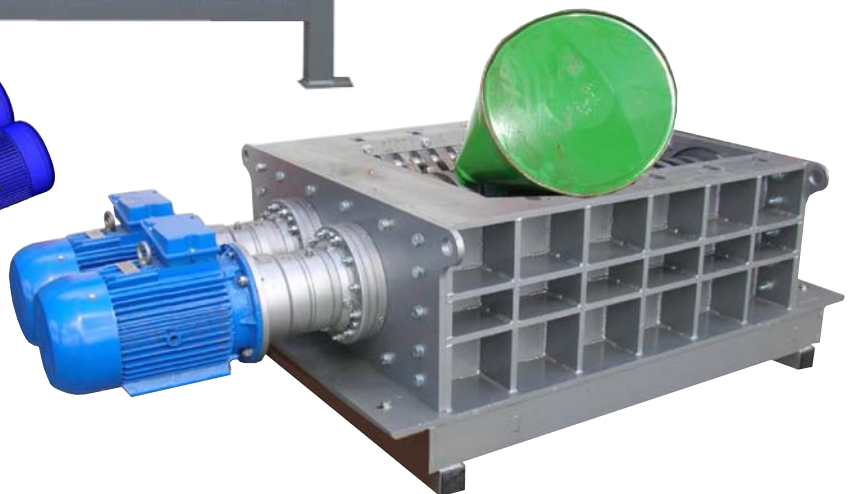
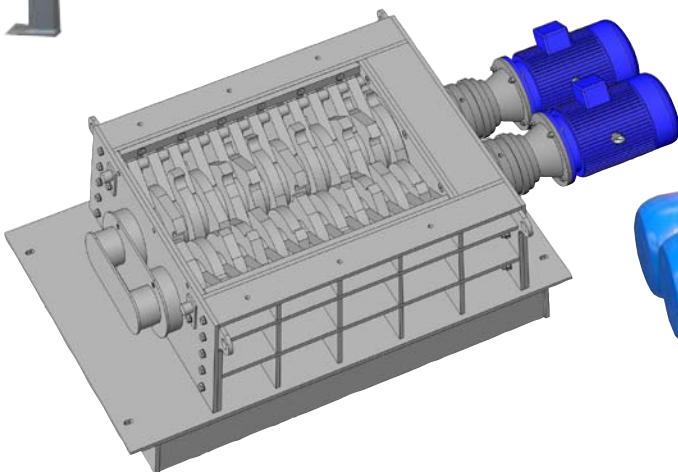

BLiK



**BLIK - Waste Recovery
and Processing Equipment**
Z.I. de Chenet
91490 MILLY-LA-FORET
E.mail: blik@blik.fr

www.blik.fr

telephone:
33 (0)1 64 98 79 79
fax:
33 (0)1 64 98 79 78

page
1

ADVANTAGES:

Slow Rotation, silent, no vibration

Electric Control, planetary gearbox for a crushing without blows

Regular rotation of the shafts thanks to the electronic system of regulation according to the load of the crusher

Automatic greasing for protection of the bearings and elements of transmission against acids, fluids and dust

Commands adaptable to the products to be crushed thanks to the system of electronic inversion integrated

Easy maintenance, rigorous quality control



B840-1250 during installation, before installing the base and switch box

Name	B840/750	B840/1000	B840/1250
Size of cutting block mm	758 x 840 mm	1008 x 840 mm	1250 x 840 mm
Number of shafts	2	2	2
width of blades	500/540 mm	500/540 mm	500/540 mm
Number of blades thickness 40 mm	19	25	32
Number of blades thickness 50 mm	15	20	25
width of shafts	150 mm	150 mm	150 mm
rated rotation speed	10/21 tpm	10/21 tpm	10/21 tpm
kW	30 kW	30 kW	30 kW
Power	400 V	400 V	400 V
Protection fuse	63-120 A	63-120 A	63-120 A
Approx. weight	3300 kg	3700 kg	4200 kg
Electronic control: automatic reverse-start-stop overload			

French design and manufacture - "CE" certified - 1 year guarantee (*) - Subject to technical and optical modifications



BLIK crusher B840/750 with automatic rammer

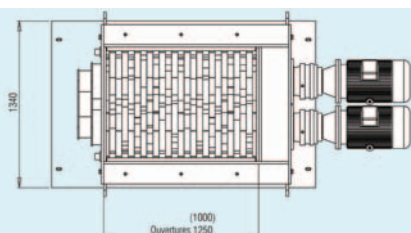
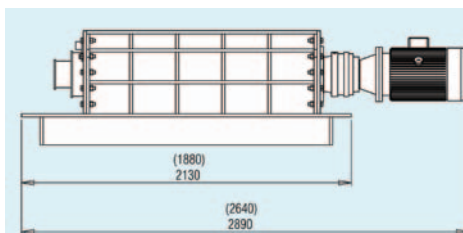
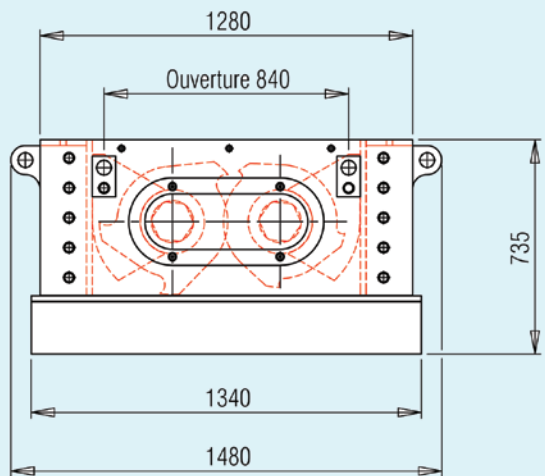

BLiK CRUSHERS B 840 Serie, 2 Rotors (continued)

Crushing and sorting equipment: input conveyor, crusher B840, magnetic sorting by overband, removal conveyor



Hardware power to grind



after sorting overband: plastic



Printers larger models



after crushing, sorting is facilitated



the same material after grinding



Pallets of computer equipment to power grind

input conveyor, crusher B840, magnetic sorting by overband, removal conveyor

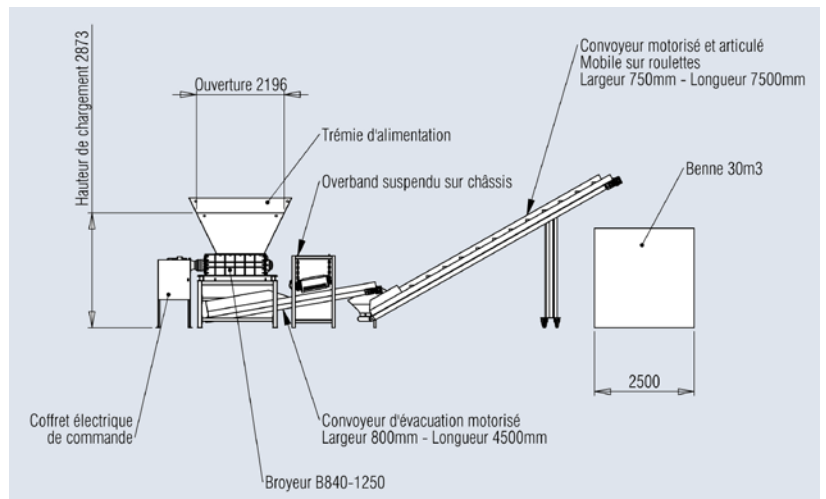
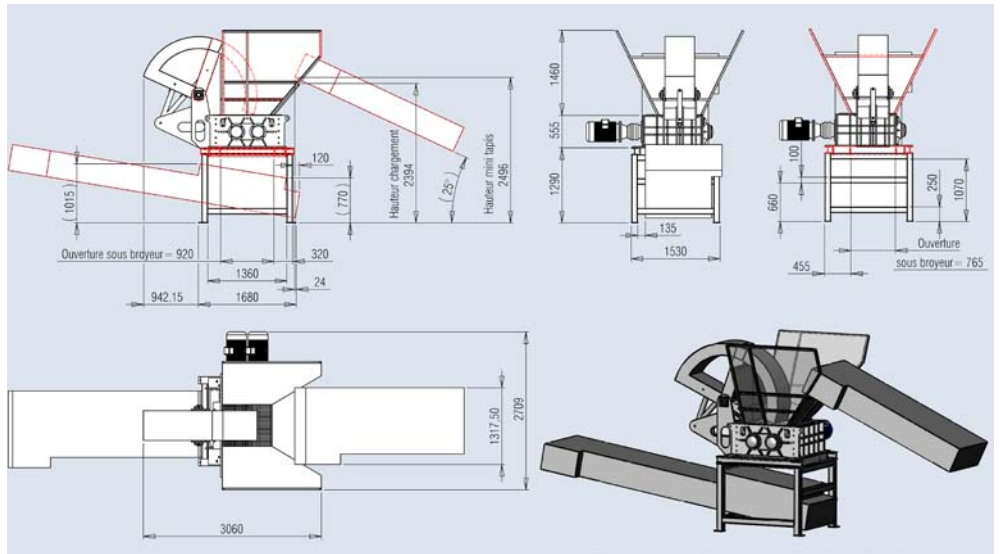

BLiK CRUSHERS B 840 Serie, 2 Rotors (continued)

B 840-1250, destruction of pallets and wood cases, with separation of the metal points, and evacuation out of 30 M3 containers



Blik B840 crusher



Overview



Untreated material



magnetic separation of the points



Evacuation of wood



Filling of the bucket



Crushing of parts of automobile body

B 840-1250

