

BLIK CRUSHERS MONOROTOR "M420-530 & M420-700"

SPECIALLY DESIGNED FOR COMMUNITIES AND RESTAURANTS

This crusher was designed for eliminating a variety of materials and waste products which normally occur in reprocessing, trade or services.

It is used for general destruction and for reducing the volume of hard, hollow objects such as bottles, plastic barrels, metal containers and cardboard boxes.

If jamming occurs, it automatically goes into reverse for up to 3 times before going into standby or restarting, after getting rid of the jam.

The special, highly resistant, blades can easily be disassembled and fitted onto an exclusive BLIK anti shock system.

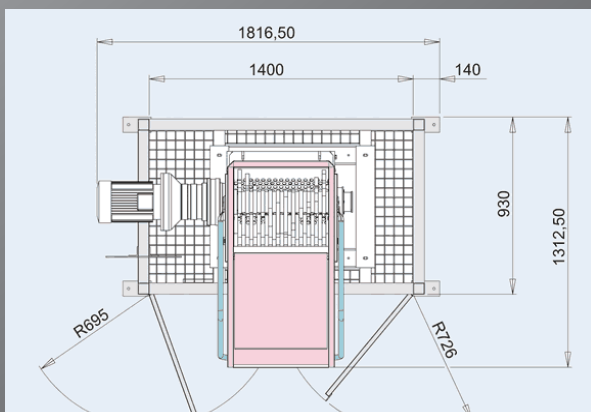
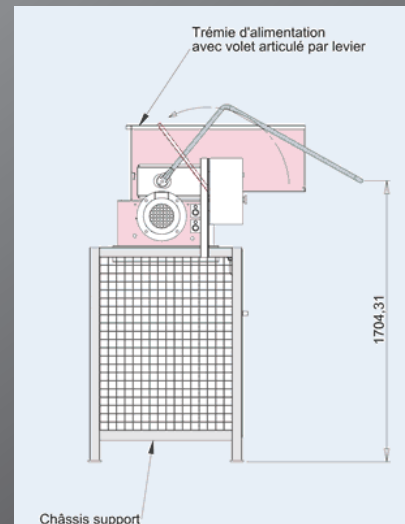
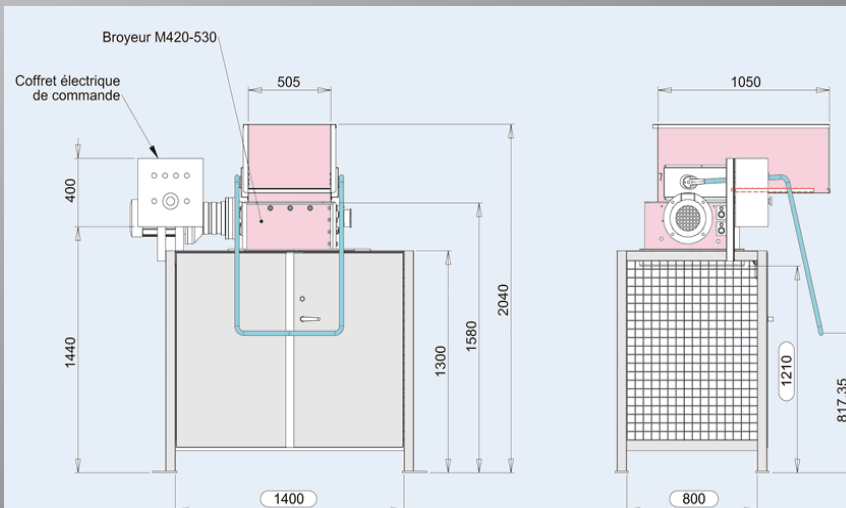

**Tilting Hopper:
Introduce your bags fast,
effortlessly and safely**

BLIK CRUSHERS MONOROTOR "M420-530 & M420-700"

SPECIALLY DESIGNED FOR COMMUNITIES AND RESTAURANTS

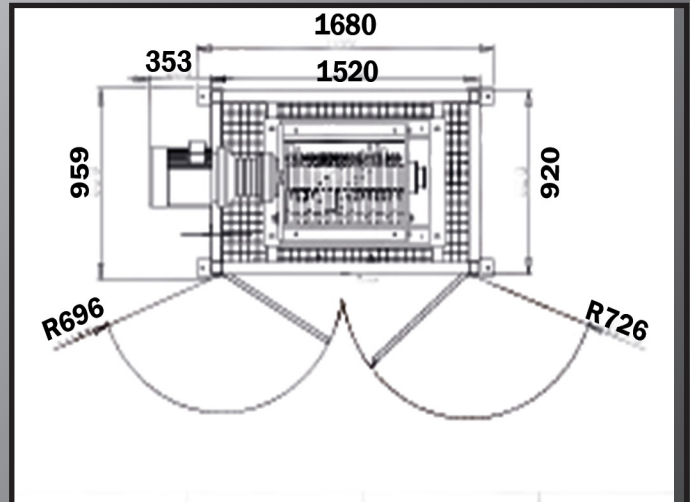

MONOROTOR CRUSHER 420-530/420-700

Type :	420-530	420-700
Cutting edge in mm	420x520	420x690
Hopper opening in mm	1200x500	1200x700
Motor in kW	7,5 KW/400V/50Hz	7,5 KW/400V/50Hz
Number of rotors	1	1
Blade width in mm	340	340
Blade thickness in mm	24	20
Number of blades	12	16
Rotation speed in tr/min	19	19
Number of hooks per blade	1	1
Dimensions cutting block only (L x D x H)	1200 x 650 x 1000	1685 x 640 x 450
Weight of machine in kg	500	590

**ELECTRONIC CONTROL: AUTOMATIC REVERSE-START-STOP OVERLOAD
MATERIAL 1 YEAR GUARANTEE**

BLIK CRUSHERS MONOROTOR "M420-530" SPECIAL CARDBOARD CORE



**THIS SPECIAL VERSION OF THE M430-530
INCLUDE A LONG HOPPER AND A TILTED
SCREW HAS BEEN SPECIALLY DESIGNED TO
CRUSH CARBOARD CORE**

