

BLIK CRUSHERS SERIE B840/750-1250, 2 ROTORS

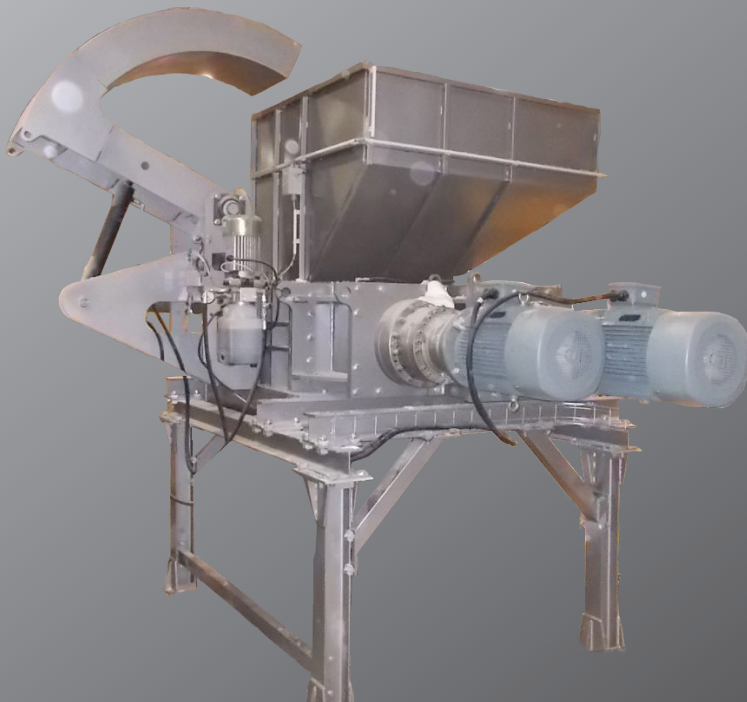

B840-750 with big electric arm (view from behind)



B840-750 with big electric arm (view from front)

ADVANTAGES:

Slow Rotation, silent, no vibration
Electric Control, planetary gearbox for a crushing without blows

Regular rotation of the shafts thanks to the electronic system of regulation according to the load of the crusher

Automatic greasing for protection of the bearings and elements of transmission against acids, fluids and dust.

Commands adaptable to the products to be crushed thanks to the system of electronic

Easy maintenance, rigorous quality control.

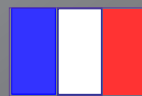

**French
design and
manufacture**

POSSIBLE OPTIONS

- VL Tires
- Steel barrels
- Plastic containers
- Batteries for cars
- Bulky refuse
- Special Waste
- Pallets

BLIK CRUSHERS SERIE B840/750-1250, 2 ROTORS

SOME APPLICATIONS OF THE B840 CRUSHER



B840-1250 with evacuation conveyor and magnetic sorting by overband in order to crush pallets



Wood evacuation after separation of the metallic points.



Computer equipment to crush



After magnetic sorting by overband : the plastic



After shredding, the sorting is way easier



Paint buckets to crush



Paint buckets after shredding

BLIK CRUSHERS SERIE B840/750-1250, 2 ROTORS

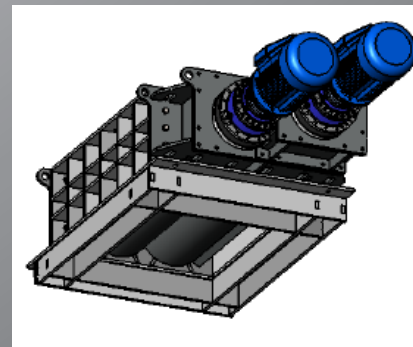
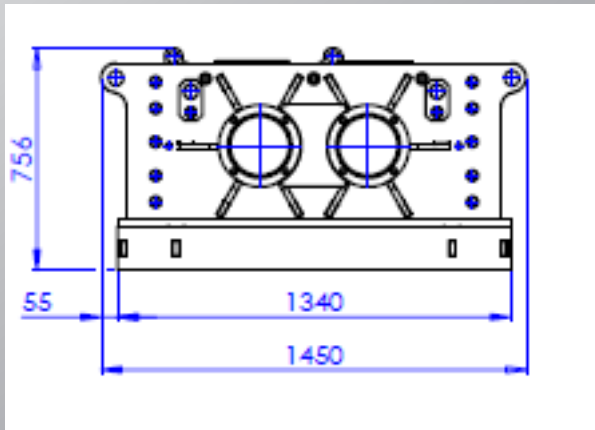
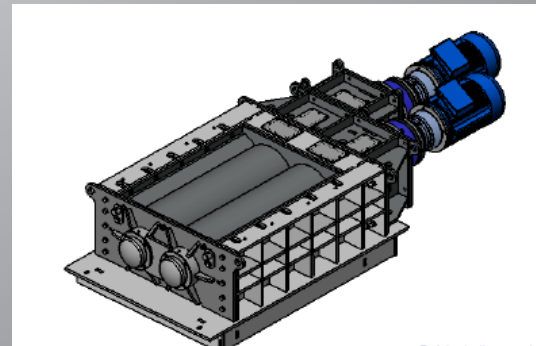
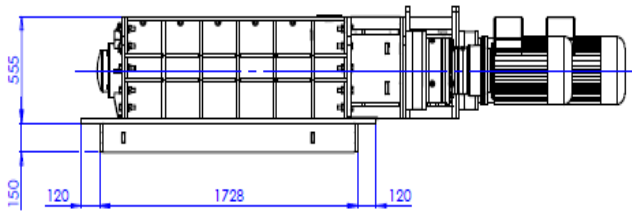
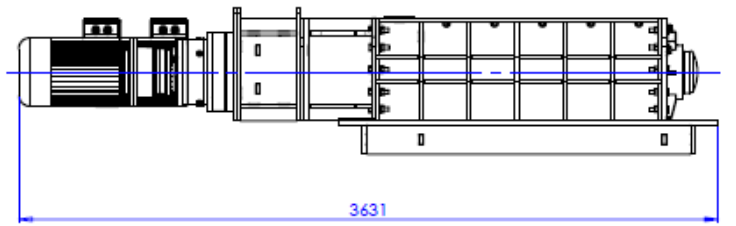
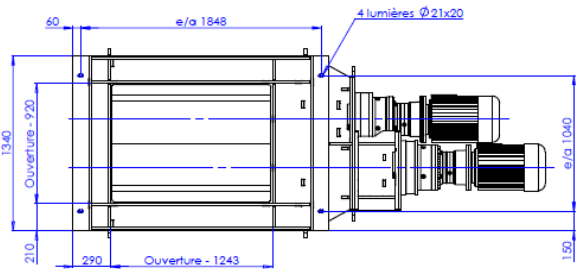

GENERAL TECHNICAL SPECIFICATIONS (*) B840 SERIES

Cutting block mm	840 x 750	840 x 1250
Hopper Opening mm	adaptable	adaptable
Alimentation kW/V/Hz	2 x 22 kW/400V/50Hz	2 x 22 kW/400V/50Hz
Output torque gearbox min / max in N.m	20850 / 31275 N.m	14183 / 21274 N.m
Number of shafts/ Blade width in mm	2 / 500-540	2 / 500-540
Blade thickness in mm	20 / 40	20 / 40
Number of blades	38 / 19	38 / 19
Rated rotation en tr/min	10 / 7	10 / 7
Number of hooks per blade	1 / 3	1 / 3
Dimension cutting block only L x D x H	2390 x 1480 x 735	2890 x 1480 x 735
Frequency variator on each engine	Yes	Yes
Automatic greasing system	Yes	Yes
Approx Weight	4000	4500

ELECTRONIC CONTROL: AUTOMATIC REVERSE-START-STOP OVERLOAD

1 YEAR GUARANTEE MATERIAL «CE» CERTIFIED